

MI'S

HIGHWAY KART

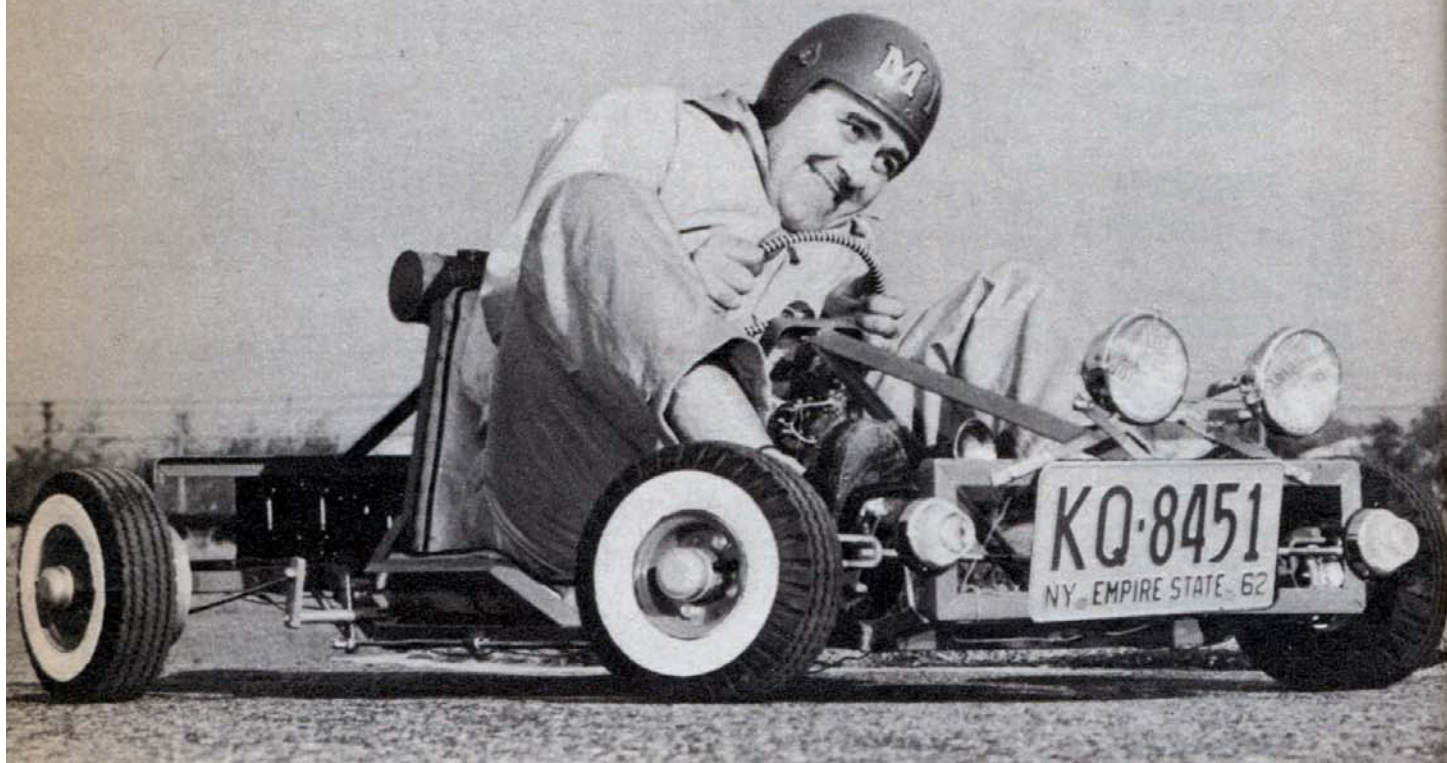

You don't need a trailer or a station wagon to haul this kart to a track—you can drive it there on public roads!

By R. J. Capotosto

D RIVING a kart is a real thrill. Seated on a low-slung frame only inches from the ground, you feel as if you're doing 80 mph when you're doing 20. Yet it's surprisingly safe. The low center of gravity and a width two-thirds the length make it almost impossible to flip a kart in a tight turn. Just about everyone who tries a kart gets the urge to own one—and if you've got that urge, you get a bonus in building the MI Highway Kart.

Since karts are generally driven on special tracks, it is not necessary to register them. However, transporting a

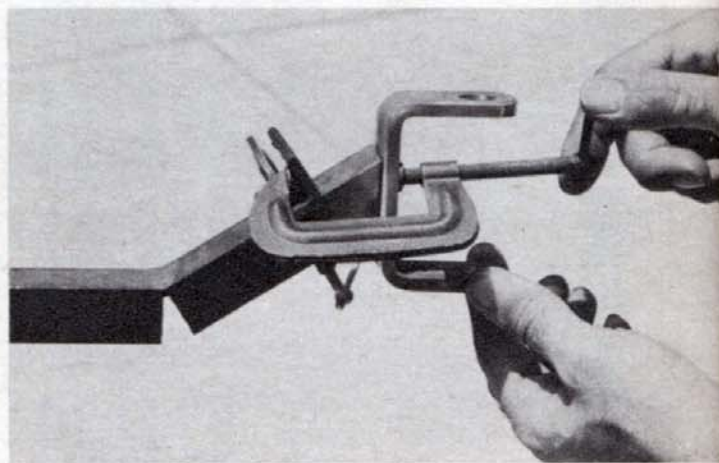

CLAMPS and a piece of angle-iron hold kingpin brackets in position for welding.

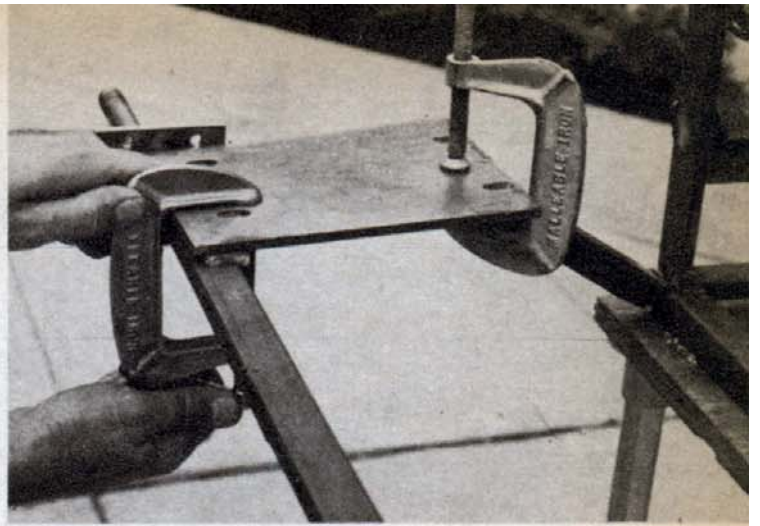
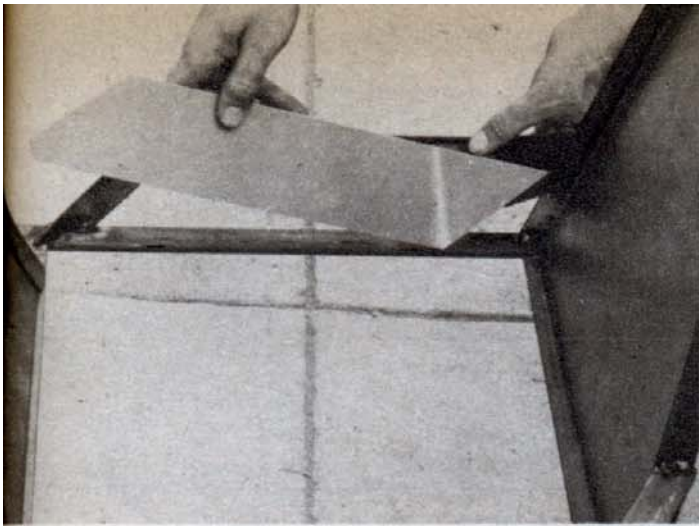

•SHEET STEEL is cut and bent to shape, then spot-welded beneath the sissy rails.

ENGINE MOUNTING plate is tack-welded at first since it may require shifting later.

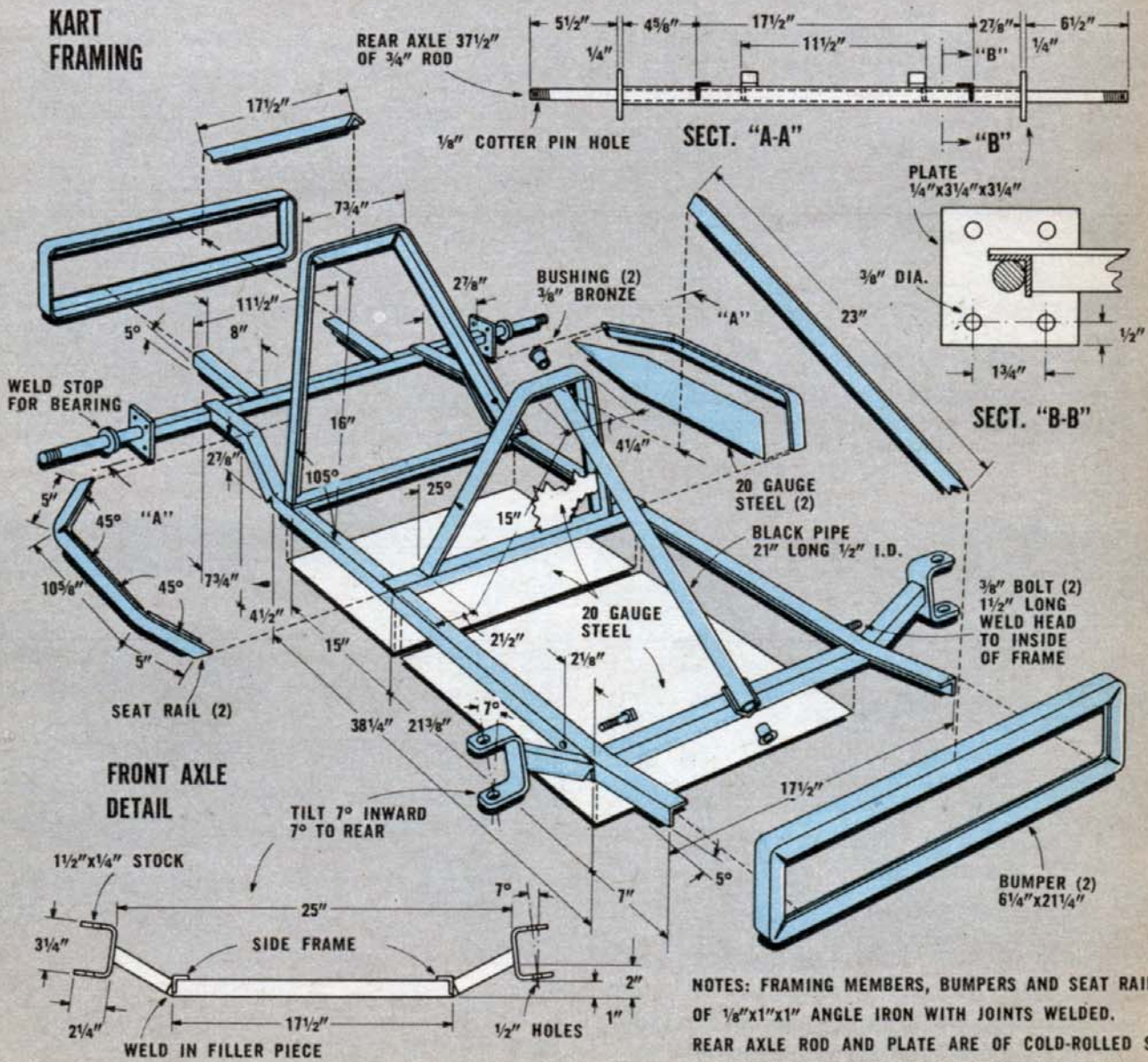

NOTES: FRAMING MEMBERS, BUMPERS AND SEAT RAILS ARE OF 1/8" x 1" x 1" ANGLE IRON WITH JOINTS WELDED. REAR AXLE ROD AND PLATE ARE OF COLD-ROLLED STEEL. FRONT AXLE BRACKETS ARE OF HOT-ROLLED STEEL.

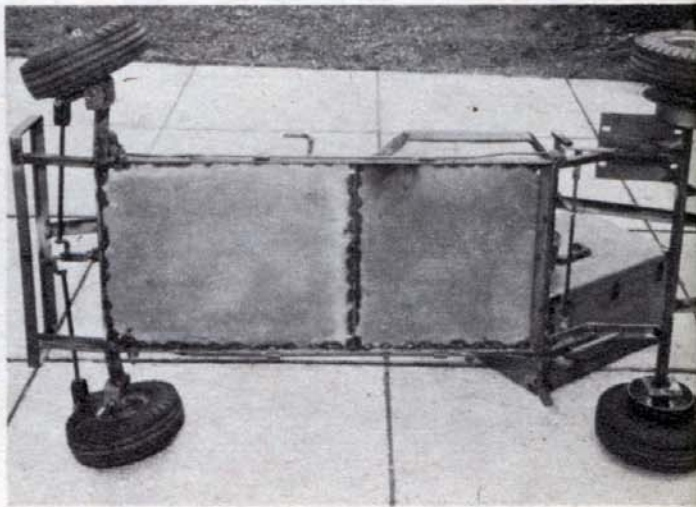
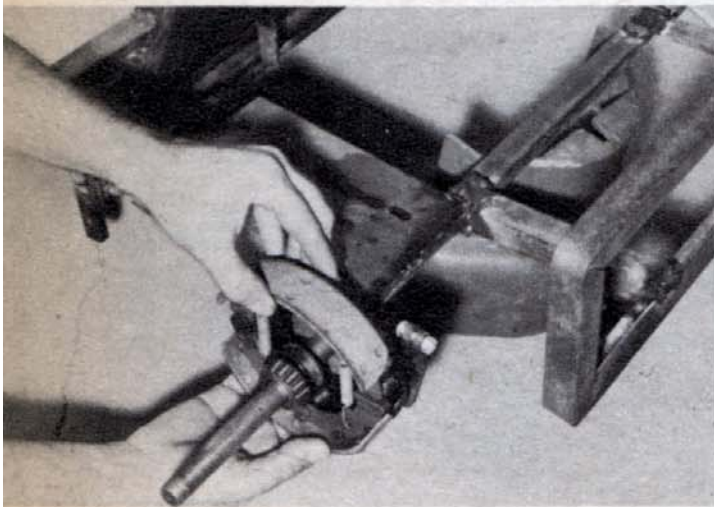
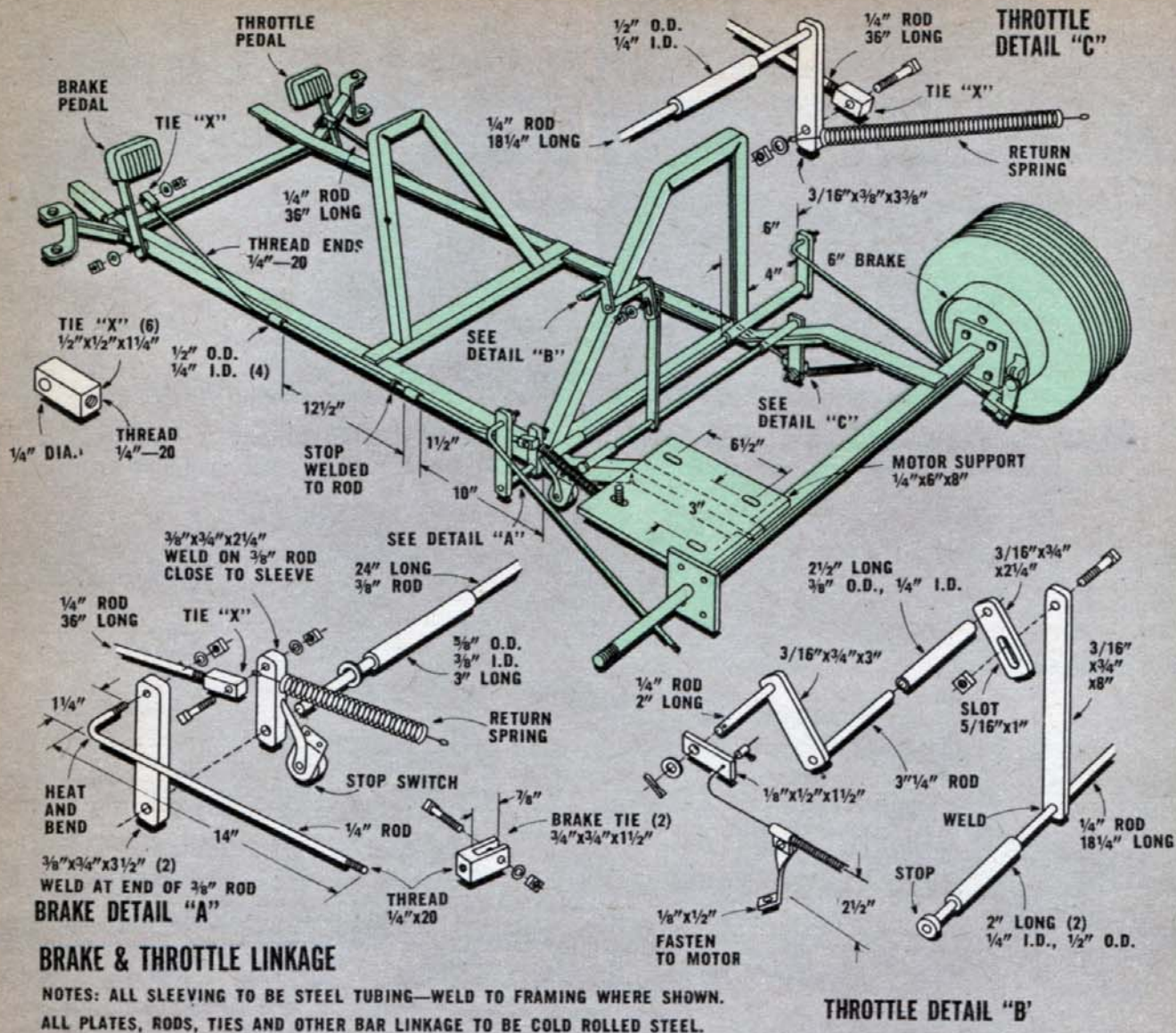

BRAKES are the internal expanding type. Two are needed for kart used on highways.

BOTTOM view with the belly pan welded in place. Note bends in the control rods.

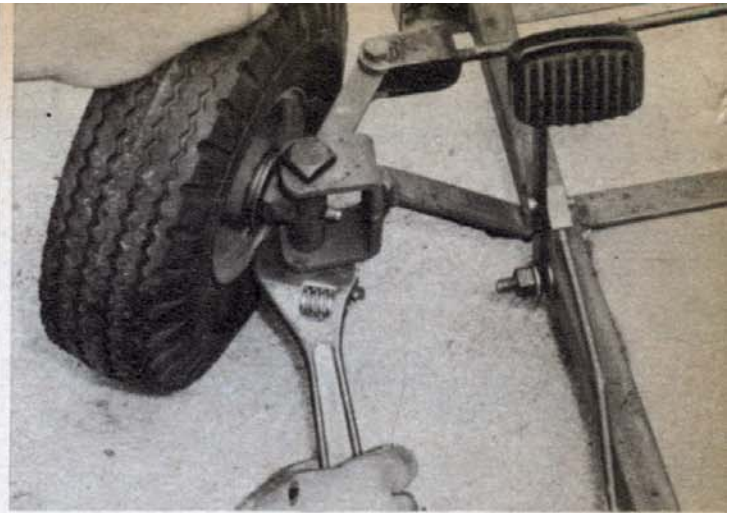
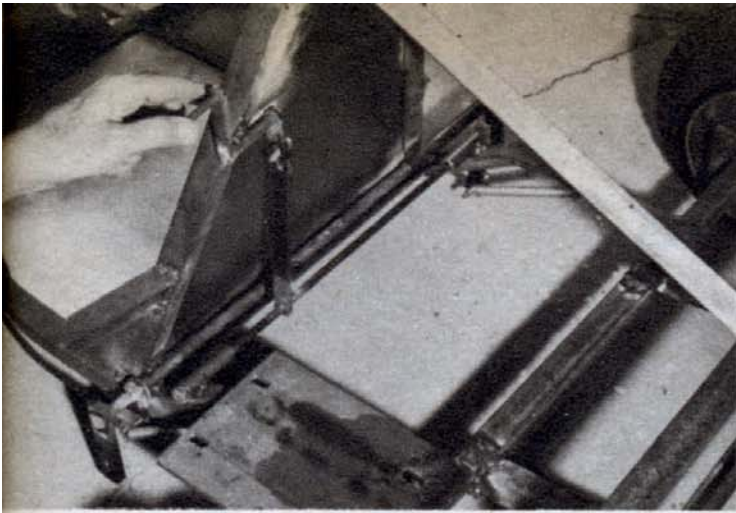

THROTTLE control linkage is simple but foolproof. Return spring is on the right.

DON'T overtighten the nut on the king-pin. Use a slotted nut and a cotter pin.

KING-PIN ASSEMBLY DETAIL

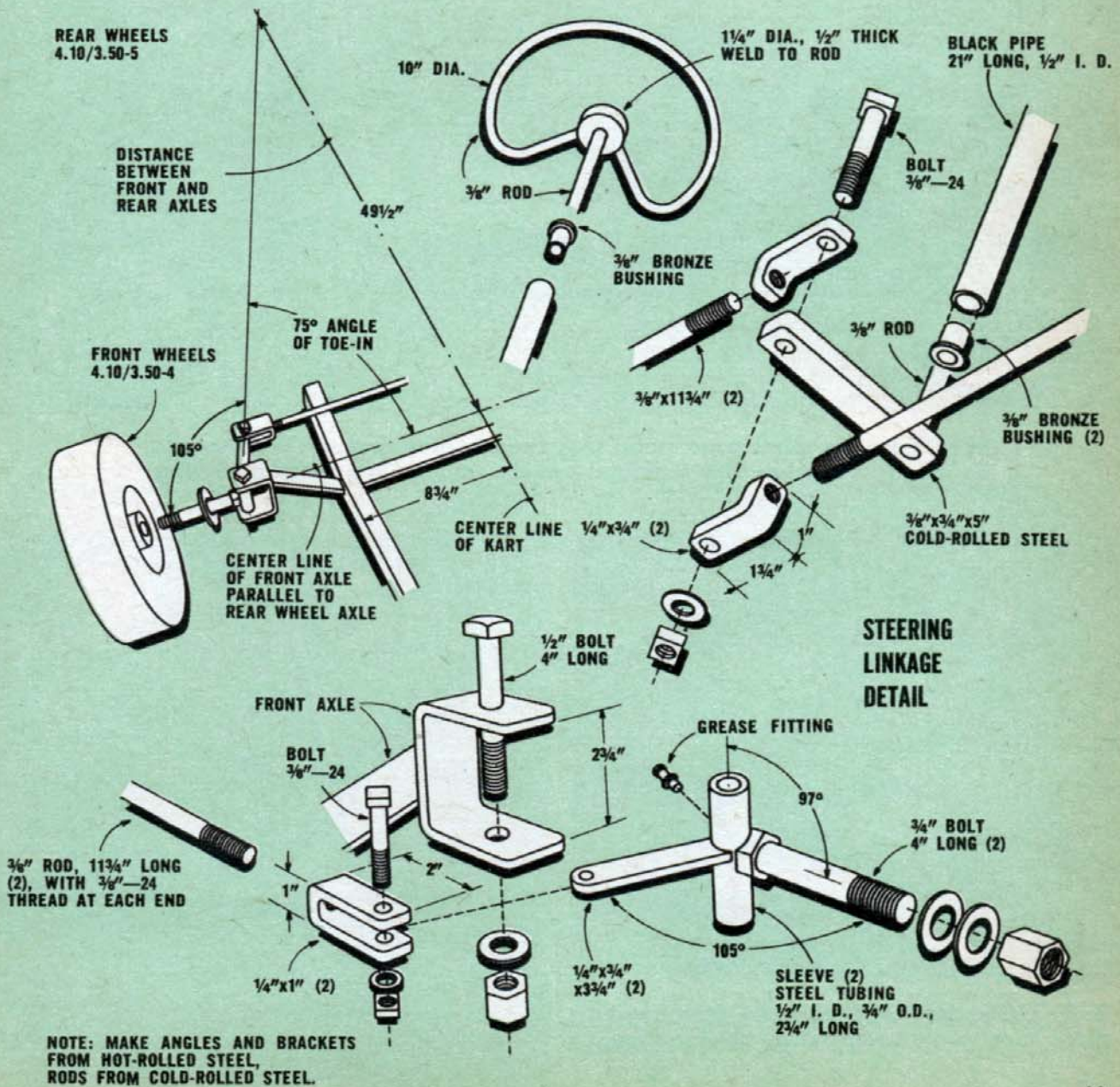

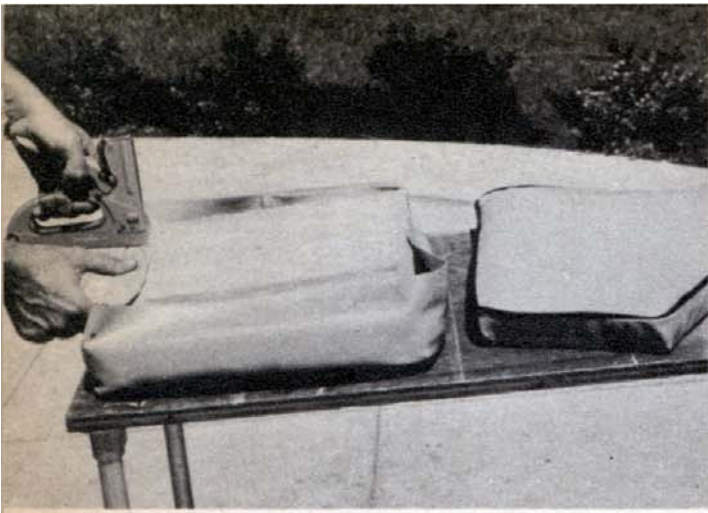

CUSHIONS are foam rubber. A Boltflex cover is stapled to the plywood backing.

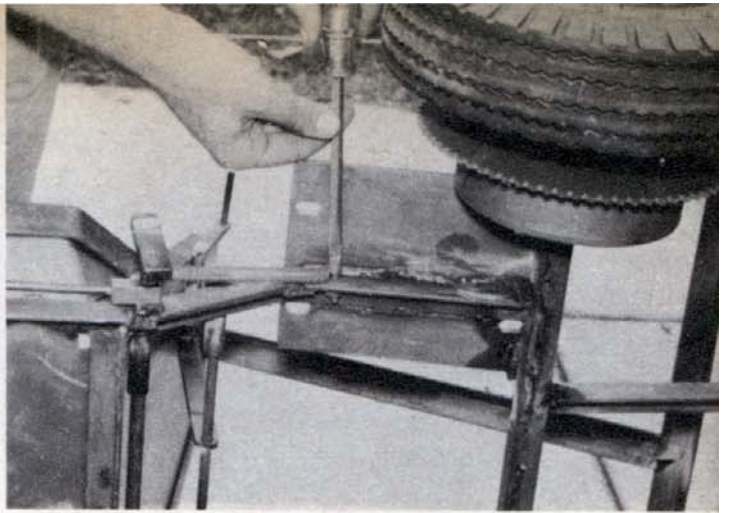

RETURN spring connected to brake linkage is strong enough to pull pedal back.

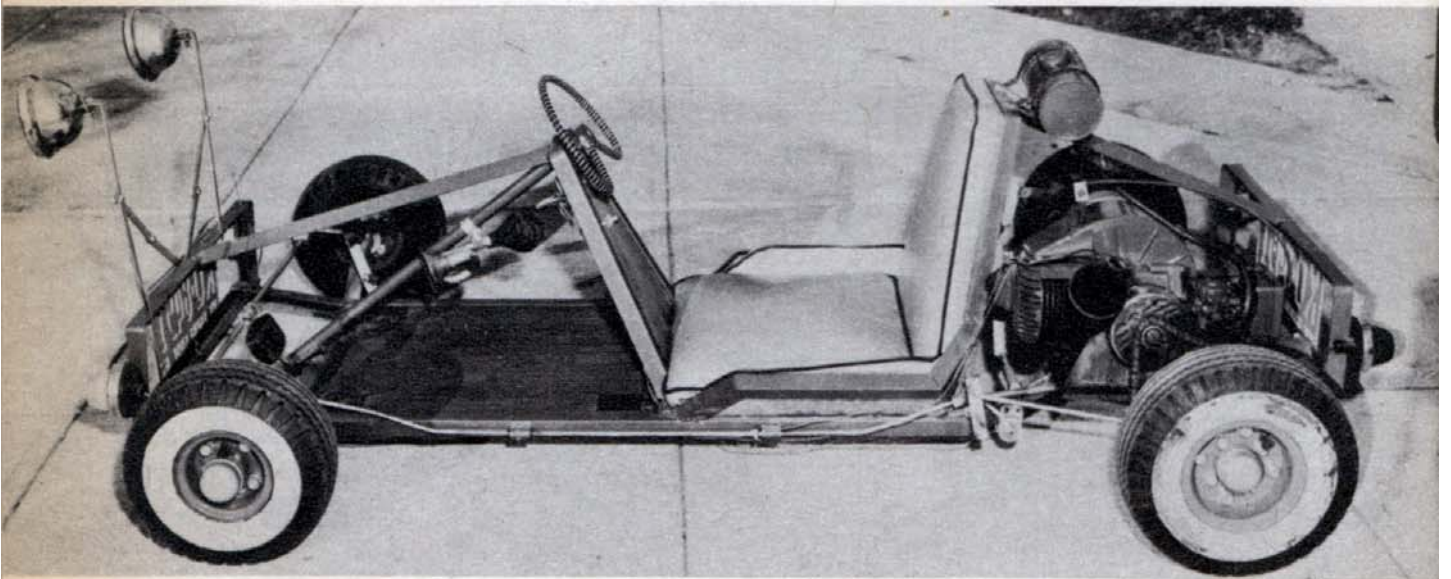

READY for the road. Latex paint was used to give tires white sidewalls. Headlights 24 inches above ground comply with the law for night driving.

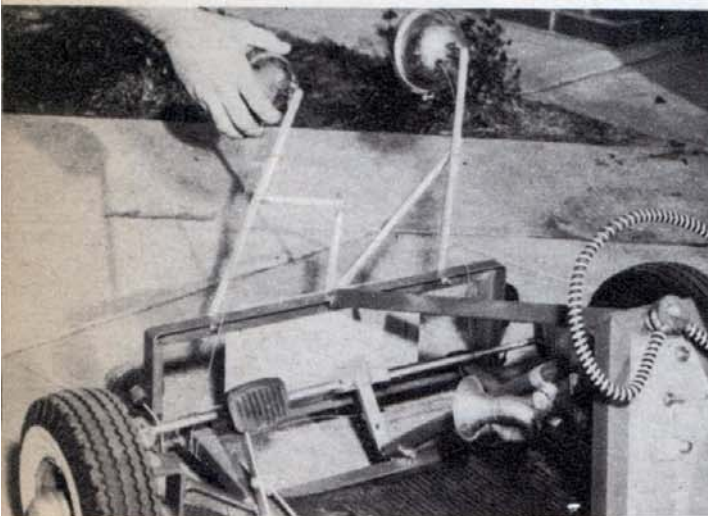

BRACKETS are adjustable so that headlights may be lowered when not required.

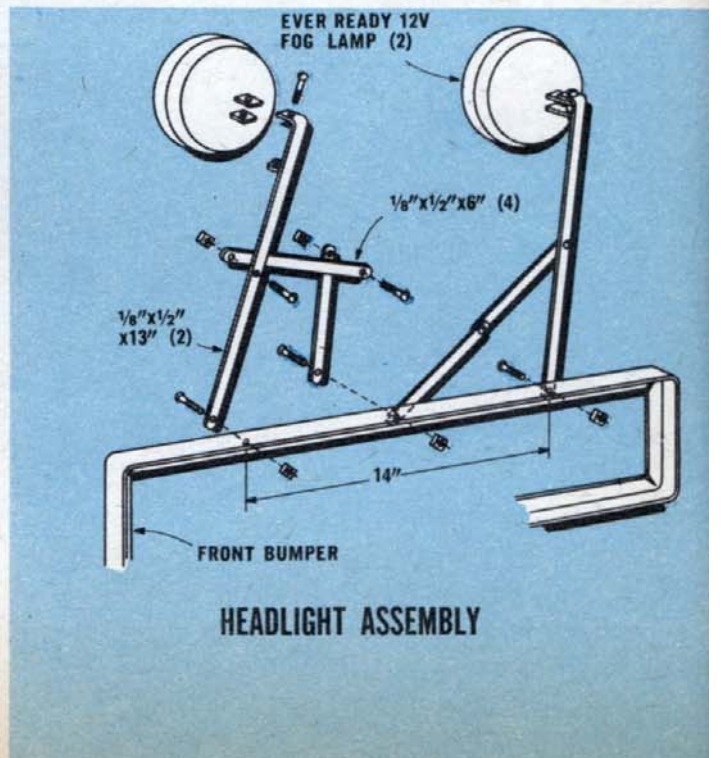

kart is often a problem. It can be hauled in a station wagon—if you own a wagon—or it can be towed on a trailer. Either way, the lugging can be quite a nuisance. With this in mind, our model was designed so that registration could be obtained, making it possible to drive the kart to its destination on public roads.

Our plates were obtained in New York. However, regulations vary and the requirements would have to be checked in other states. First we had to supply three things: proof of ownership (a bill of sale for the engine); an affidavit stating that the kart was built by ourselves; and a list of the parts used. To make the kart legally roadworthy it had to have front and rear bumpers, a brake on each rear wheel, headlights, taillights, turn signals, a rear license plate and a horn. In use, the head-

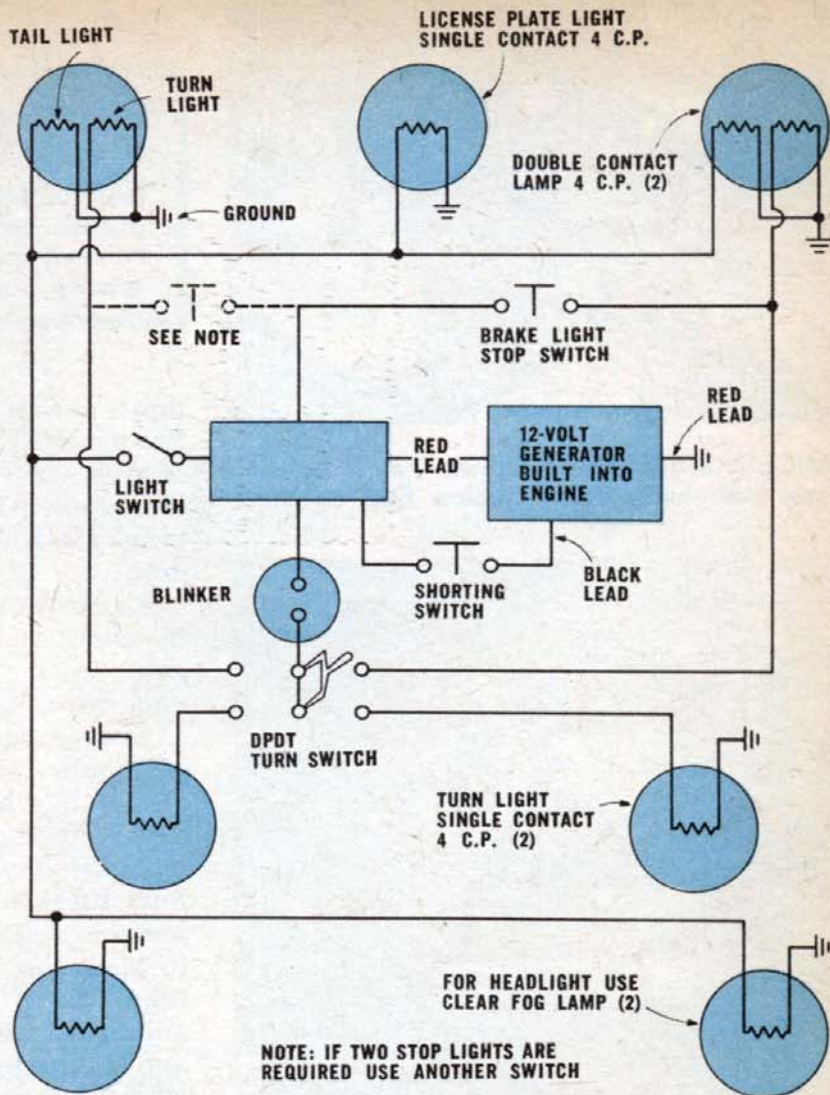

WIRING DIAGRAM FOR 12-VOLT SYSTEM

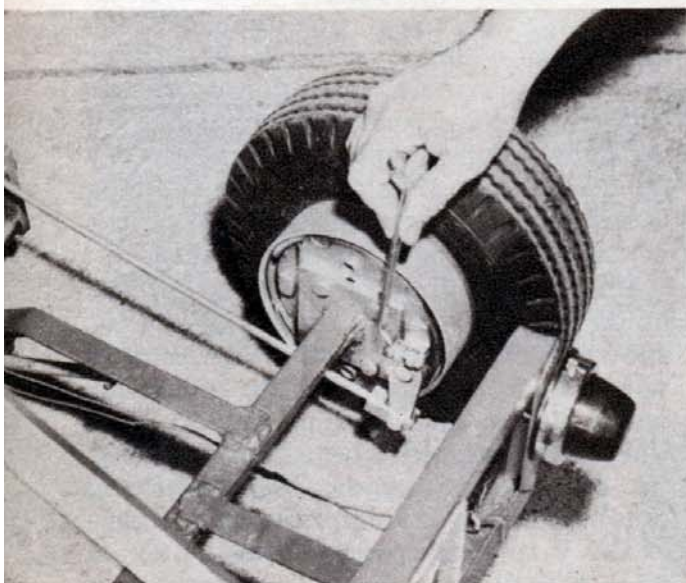

WITH TWO BRAKES, the linkage must be set so that both will be applied at once.

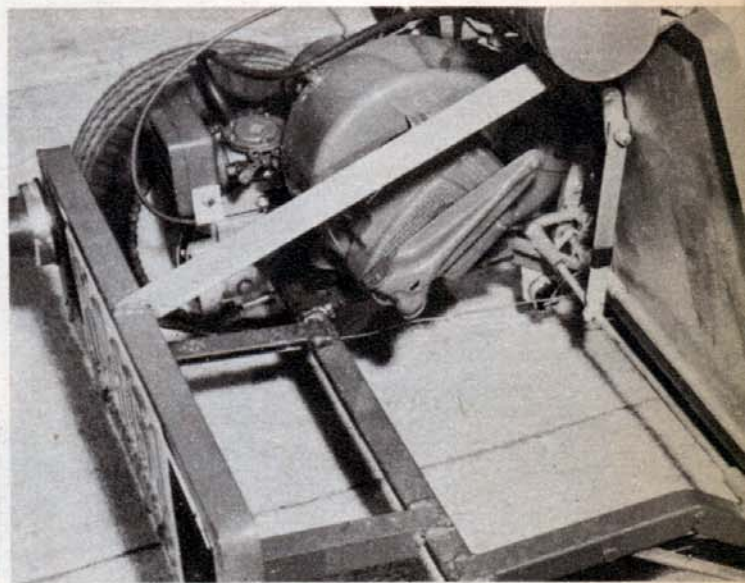

HAND CRANK for engine's impact starter folds up out of the way when not in use.



MICRO MUFFLER is shown being bolted over exhaust port of Clinton E-65 engine.

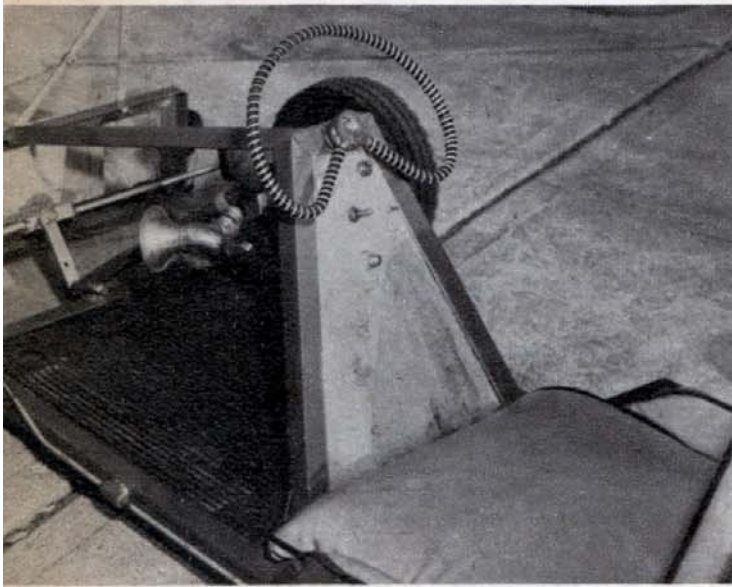

LIGHT switches and a switch for shorting out engine are on panel below wheel.

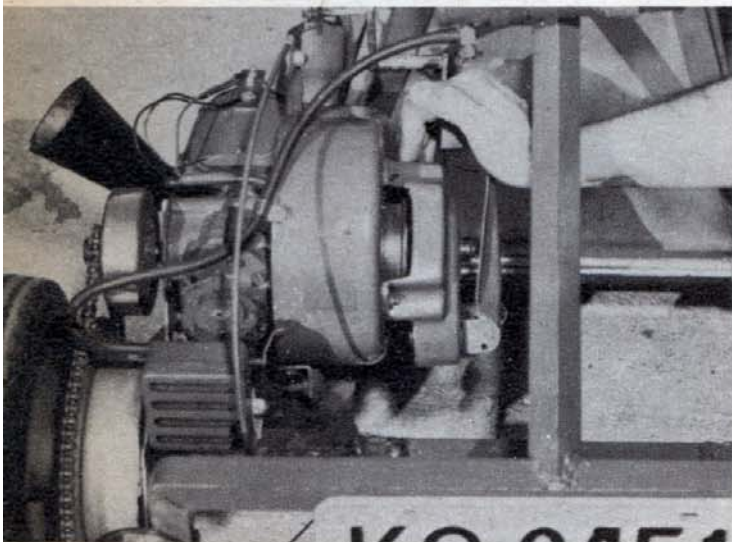

CRANK is pressed after four turns, releasing a spring which starts the engine.

LARGE-SCALE PLANS

are available with complete text and photos. Send \$3 to MI Plans Service, Fawcett Bldg., Greenwich, Conn., and specify Plan WB-4, MI's Highway Kart.

lights are required to be 24 inches above the ground. A permanent arrangement of this sort would not be desirable, so we mounted the lights on adjustable brackets which allow them to be lowered.

Electrifying the kart was simplified by using a Clinton E-65-1100 series engine with a built-in, 12-volt flywheel generator. This eliminates the need for a heavy battery, relay and external generator. The engine delivers 5.2 hp and it has a 5.76 cubic inch displacement, putting it in the Class A category. It is fitted with an impact starter and four turns of the crank followed by a press to release the spring are sufficient to start the engine. A Mercury centrifugal clutch permits no-load starting and load-free idling and it automatically applies the load to the engine at its most efficient speed. Brakes are the six-inch internal expanding type. If you do not plan to register the kart, one brake will be sufficient as a Class A rig.

For simple and sturdy construction, angle-iron is used throughout. This eliminates welding of fish-mouth joints on tubing, something which is rather difficult unless you're an experienced welder. Welding angle-iron is very easy by comparison. It's also easy to shape the angle-iron by cutting slits or notches in one side and bending it in a vise.

Start construction by cutting all the angle-iron to size and forming it as shown in the drawings. Cut the notches with a hack saw and save the triangular waste pieces. These can be used to fill in the spaces formed where the slits open up on reverse bends. When cutting notches, drill a $\frac{3}{16}$ -inch hole at the base of the V to allow proper bending clearance. File all cuts clean to remove burrs prior to welding. The $\frac{3}{8}$ -inch holes for the brake and [Continued on page 112]

Test your automotive I.Q!

QUICK QUIZ BY QUAKER STATE



1. Can you identify this device?

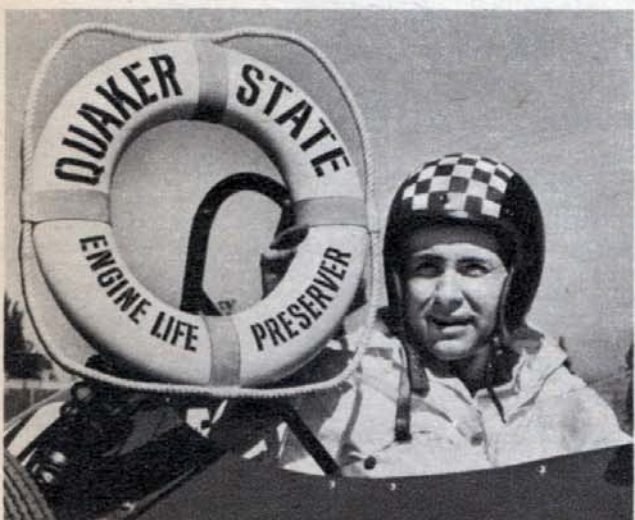

2. What does this symbol stand for?

The device at top is a valve-lash adjuster. The life preserver stands for Quaker State Motor Oil—because it is the best engine life preserver. Refined from 100% pure Pennsylvania Grade Crude Oil, it keeps your car on the road, out of the repair shop—and saves you money. Always insist on Quaker State—the best engine life preserver.



QUAKER STATE OIL REFINING CORP., OIL CITY, PA.

Highway Kart

[Continued from page 96]

throttle studs should also be drilled at this time.

To simplify the welding, clamp the pieces together and tack-weld them first. Then check the positioning to see if it's all right to complete the welds. We used a Lincwelder 100 and obtained excellent results.

The $1\frac{1}{4} \times \frac{1}{2}$ -inch kingpin brackets should be clamped in perfect alignment before they are welded in place. These brackets are made by heating the metal to a cherry red and then bending them in a vise. If your welder is equipped with a carbon-arc torch, you will find it excellent for heating the metal. The rear axle and brake flange are also attached at this time. Note that the rear axle is offset to allow for the sprocket on the left side.

The engine mounting plate is made from quarter-inch steel plate. It has elongated slots to allow for proper alignment of the engine. A simple way to make the slots is to drill the two end holes and cut out the material between. Use a keyhole saw or, better still, a jig saw with a fine-toothed blade and a slow speed. Wax the blade and feed the work slowly. Since this plate may have to be moved slightly on final assembly, tack-weld it into place.

The throttle and brake linkages are assembled as shown in the drawings. Make the control rods from quarter-inch cold-rolled steel, threaded at each end. Temporarily attach the rod assemblies to the frame, clamping them at the stop guide brackets. The rods should not bind when the pedals are operated. The return springs should also be in place at this time so that proper tensioning and positioning is obtained. When all checks out, the units can be assembled to the frame.

The firewall, belly pan, dash and side pieces under the sissy rails are cut from 20-gauge sheet steel with heavy-duty shears. Bending is required to fit the side pieces into place. Attach all these plates by spot-welding every inch.

The steering knuckles are made by welding $\frac{3}{4} \times 4$ -inch cap screws to steel tubing of half-inch inside diameter. Drill and tap the tubing to accept a grease fit-

[Continued on page 116]

**STOPS ALL
"TOOL FUMBLING"**

**challenger
"Pick-Quick"
SOCKET SETS**



You PICK THE
'CORRECT SOCKET
OR ATTACHMENT
INSTANTLY . . . BECAUSE
EXACT "CONTOURS"
KEEP TOOLS ALWAYS IN CORRECT PLACES

No lost motion—saves you time—ends frustration. Every Socket and Attachment is always in same place . . . always in full view with size printed below it . . . always ready for fingertip removal! When not in use, closed lid of box locks tools in position. **Top-Value throughout, yet costs you no more than ordinary socket sets.** All tools are long-life Alloy Steel, lightweight, streamlined, finely-machined, chrome plated, engineered for accurate performance. **Factory Guaranteed.**



**CHOOSE FROM 20 SETS IN 1/4"
1/4" 3/8" 1/2" SQUARE DRIVES**

Dr. You'll find the exact set you need in the "Pick-Quick" line. Also get details on Challenger's finely-made, economy-priced wrenches, pliers, screwdrivers, hammers, chisels, etc. See your local dealer . . . or write address below.

★ MADE IN AMERICA ★



SCHILLER PARK, ILLINOIS

SUBSIDIARY OF



Highway Kart

[Continued from page 112]

ting, taking care to remove any burrs that may form on the inside. The cotter pin hole in the axle also may be made at this time. Determine the location of the hole by placing the wheel with bearings on the axle. Then remove the wheel and thread a nut onto the axle, noting the exact location of the hole. Lock the nut in place with a second nut and then drill through the flat side of the nut. The wheels, incidentally, are available from the Indus Corp., 1815 Madison Ave., Indianapolis 25, Ind.

The steering tie rods are threaded at each end for a distance of one inch so that there will be sufficient adjustment for toe-in. The steering rod and wheel are made of 3/8-inch cold-rolled steel. The large bend in the wheel may be made cold but the sharp bends will have to be heated. The 3/8-inch bronze bushings are pressed into the top and bottom of the steering rod tube. A plastic mallet is good for driving them in. As an added safety feature, the wheel and arm are welded to the steering rod after assembly. Make sure that the arm is in alignment with the steering wheel before welding.

The carburetor throttle lever is connected directly to the throttle linkage through a length of throttle cable. Attach the cable to the body of the engine with a bracket made from a scrap of 20-gauge steel. The separate gas tank is mounted directly behind the driver's seat, again using 20-gauge steel for straps.

The electrical system is next added by following the wiring diagram. Use stranded wire and tape all the leads in a neat bunch so that none will dangle. The taillights and turn lights are screwed directly to the frame by drilling small holes at the rear of the fixtures. The stop light switch must be positioned so that it closes the circuit when the brake pedal is depressed one half of its travel. Naturally, the engine must be running to provide current for this test.

The upholstery consists of a quarter-inch plywood backing, a two-inch foam rubber filler and a covering of Boltaflex, a product of Bolta Products, Division of The General Tire and Rubber Co., Law-

[Continued on page 118]

Highway Kart

[Continued from page 116]

rence, Mass. Pull the material tight over the foam and staple it to the rear of the plywood.

The Indus wheels do not come with white walls as shown. We used a latex paint for this. Be sure to clean the rubber thoroughly before painting. All metal parts of the kart should be given a coat of metal primer before painting them with enamel. The lamp brackets, control rods, etc., are sprayed with aluminum paint. To add to the looks of the kart, a ribbed rubber floor mat is used.

Due to the space limitations where the engine is positioned, it is not possible to make full turns of the impact starter crank. However, the crank is connected through a ratchet and full turns are not necessary.

Our kart, including everything but the engine, was built for \$116. The 5.2-hp engine with built-in 12-volt generator was \$85.74, bringing the total cost to \$201.74. Naturally, you can build the kart for considerably less if you don't want to include the features necessary for highway use. MI has made arrangements with the Finecrafts Products Co., Box 7031, Jersey City 7, N. J., to supply readers with the parts for this kart. Write to them for a price list. •

Your New Pontiac

[Continued from page 109]

third 200. Sustained high speed is ruled out until this three-part schedule has been completed. Another good piece of advice is to drive moderately for 10 or 15 minutes to allow the engine, transmission and rear axle to warm up.

Use only oil designated "For service MS or DG." A multi-viscosity oil is acceptable as an alternate for 20W oil at temperatures ranging between 10° F and 110° F. It's also acceptable as an alternate for 10W oil between -10° F and 93° F. Below -10° F, use 5W or 5W-20 oil. Pontiac breaks down oil change mileage and time of operation for temperatures above and below freezing. In any event, change the oil every 4,000 miles. In cold weather, change it every 30 days if that rolls around

before you have traveled 4,000 miles. Double the time factor at temperatures above freezing.

If the engine has positive crankcase ventilation, be sure to replace the metering valve every 12,000 miles or every year. Whenever the brakes are serviced, the parking brake cable should be cleaned and coated with light grease. All throttle and shift linkage joints below the steering column should be oiled every 8,000 miles for best Hydra-Matic operation. Don't get oil on the rubber grommets when doing it.

And don't forget that manifold heat control valve. It must not stick.

For a final note, Pontiac points out that gradual loss of the new car feel is not easily detected by the regular driver. That's why it's a good idea to let a Pontiac serviceman drive the car occasionally. •

Air Purifiers

[Continued from page 102]

precipitators achieve over 90 per cent efficiency. Because they are more complex they are more costly. This is evident in the sharp jump in price between purifiers using mechanical methods and those that work by precipitation. Many purifiers use ultraviolet bulbs to kill bacteria. Others use ozone bulbs which do the same work by releasing free ozone into the air. In quantity ozone can be irritating to the eyes and respiratory system but at least one leading manufacturer of air purifiers uses ozone bulbs with very few complaints.

One of the less common air treatments offered by some purifiers is negative ionization. Researchers found that the air of some health resorts noted for their bracing climate had more than an average proportion of negative ions. They also found that hospital patients in a room in which the air was ionized negatively seemed to recover more rapidly.

Not enough is yet known, however, to say exactly what are the effects of negative ionization. Manufacturers of ionizers are much more likely to be outspoken as to its benefits than are medical authorities. On the other hand the Food and Drug Administration has cracked down on manufacturers who make exaggerated claims for their purifiers. •

BUILD YOUR OWN STREET LEGAL KART (May, 1962)
MECHANIX ILLUSTRATED – THE HOW-TO MAGAZINE



Special thanks to Charles Shopsin for allowing me to use this information from his excellent <http://blog.modernmechanix.com> website.

The permalink is: <http://blog.modernmechanix.com/2006/04/03/build-your-own-street-legal-kart/>